

**PARTS LIST  
FOR  
XCELL Series  
Press Brakes**

**60 to 500 Ton Model**

**Manual Number 4911-150**

**WHEN ORDERING PARTS, BE SURE TO PROVIDE PRESS BRAKE  
MODEL AND SERIAL NUMBER**

**TABLE OF CONTENTS**

FRAME ASSEMBLY .....	2
GIBBING CONFIGURATION .....	3
CYLINDER ASSEMBLY .....	4,5
LINEAR ENCODERS .....	6,7
F800 BACK GAUGE .....	8-20
FOOT SWITCH WARNING .....	21,22

# FRAME ASSEMBLY

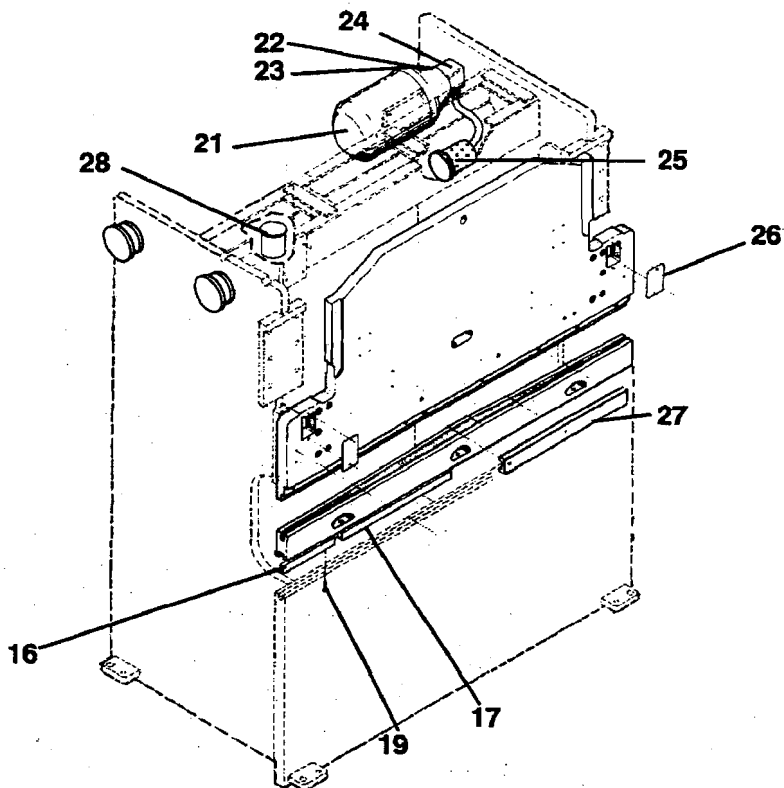

ITEM NO.	DESCRIPTION	60 TON	100 TON	140 TON	175 TON	250 TON	400 TON	500 TON
16	Key, Die Holder	7485-083	7485-083	7485-083	7485-083	7485-083	7485-083	7485-083
17	Key, Die Holder	7485-084	7485-084	7485-084	7485-084	7485-084	7485-084	7485-084
19	Screw, Soc. Hd. Cap	3303-082	3303-082	3303-082	3303-082	3303-082	3303-082	3303-082
21	Motor	4422-013	4424-013	4426-053	4426-053	4428-014	4432-014	4432-014
22	Flange, Pump	3257-061	3257-061	3257-063	3257-063	3257-073	3257-064	3257-064
23	Coupling, Motor	3428-211	3428-211	3428-218	3428-218	3428-218	3428-220	3428-220
24	Pump	3257-128	3257-208	3257-208	3257-209	3257-169	3257-177	3257-177
25	Filter, Pump Suction	3764-297	3764-297	3764-297	3764-297	3764-297	3764-297	3764-297
26	Cover, CYL. Rod Nut	7437-014	7437-014	7437-200	7437-200	7437-200	7489-017	7489-017
27	Bar, Clamp	7437-160	7437-160	7437-160	7437-160	7437-160	7437-160	7437-160
28	Filter, Return	3764-342	3764-342	3764-342	3764-342	3764-342	3764-342	3764-342

ITEM NO.	DESCRIPTION	60 TON H.S.	100 TON H.S.	140 TON H.S.	175 TON H.S.	250 TON H.S.
16	Key, Die Holder	7485-083	7485-083	7485-083	7485-083	7485-083
17	Key, Die Holder	7485-084	7485-084	7485-084	7485-084	7485-084
19	Screw, Soc. Hd. Cap	3303-082	3303-082	3303-082	3303-082	3303-082
21	Motor	4426-053	4430-014	4432-014	4432-014	4432-014
22	Flange, Pump	3257-063	3257-064	3257-064	3257-064	3257-064
23	Coupling, Motor	3428-218	3428-220	3428-220	3428-220	3428-220
24	Pump	3257-172	3257-177	3257-177	3257-177	3257-177
25	Filter, Pump Suction	3764-297	3764-297	3764-297	3764-297	3764-297
26	Cover, CYL. Rod Nut	7437-014	7437-014	7437-200	7437-200	7437-200
27	Bar, Clamp	7437-160	7437-160	7437-160	7437-160	7437-160
28	Filter, Return	3764-342	3764-342	3764-342	3764-342	3764-342

# GIBBING CONFIGURATION

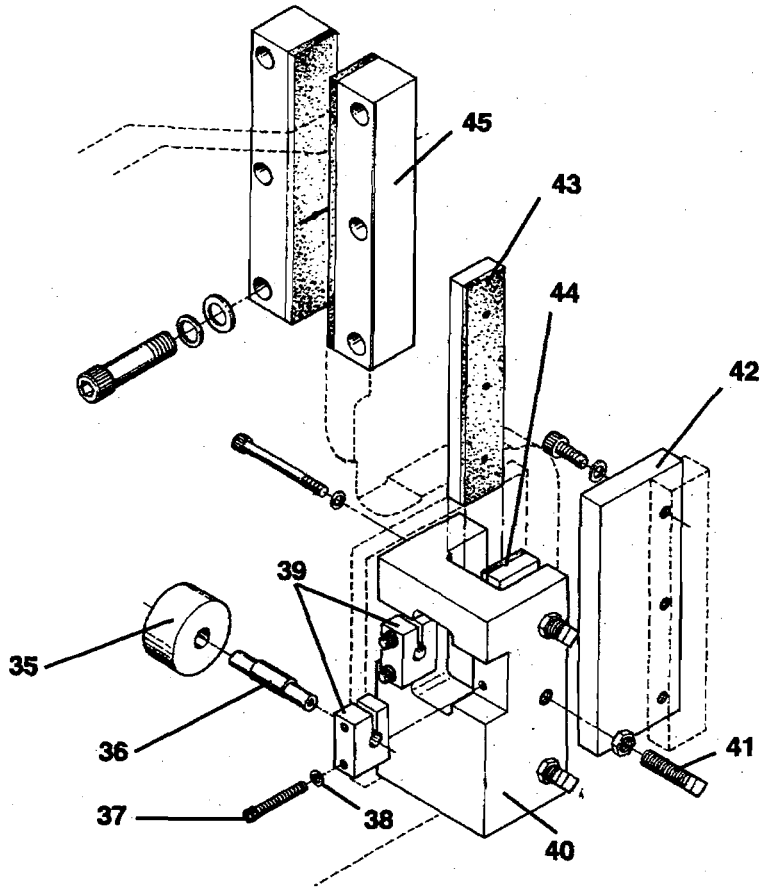

ITEM NO.	DESCRIPTION	XCELL 60	XCELL 100	XCELL 140	XCELL 175	XCELL 250	XCELL 400	XCELL 500
35	Bearing, Roller	3107-214	3107-214	3107-214	3107-214	3107-214	3107-220	3107-220
36	Shaft, Cam Follower	7437-006	7437-006	7437-006	7437-006	7437-006	7489-010	7489-010
37	Screw, Soc. Hd. Cap	3303-115	3303-115	3303-115	3303-115	3303-115	3303-115	3303-115
38	Washer, Lock	3327-007	3327-007	3327-007	3327-007	3327-007	3327-007	3327-007
39	Block, Roller Mtg.	7437-007	7437-007	7437-007	7437-007	7437-007	7489-011	7489-011
40	Bracket, Ram	7037-031	7037-029	7037-029	7037-029	7037-029	7089-011	7089-011
41	Screw, Sq.. Hd. Set	3310-036	3310-036	3310-036	3310-036	3310-036	3310-036	3310-036
42	Way, Ram	7437-004	7437-158	7437-158	7437-158	7437-158	7489-009	7489-009
43	Gib, Ram Front	7437-017	7437-155	7437-155	7437-155	7437-155	7489-005	7489-005
44	Gib, Ram Rear	7437-156	7437-156	7437-156	7437-156	7437-156	7489-008	7489-008
45	Block, Upper Gib	7437-444	7437-460	7437-460	7437-460	7437-460	7489-002	7489-002



# CYLINDER ASSEMBLY

ITEM NO.	DESCRIPTION	XCELL 60	XCELL 100	XCELL 140	XCELL 175	XCELL 250	XCELL 400	XCELL 500
57	Fitting, 8F5BUS	3822-185	3822-185	3822-185	3822-185	3822-191	3822-191	3822-191
57 HS	Fitting, 12-8F5BUS		3822-191	3822-191	3822-191			
58	Screw, Soc. Hd. Cap	3303-128	3303-127	3303-127	3303-144	3303-163	N/A	N/A
59	Fitting, 6F5BUS	3822-183	3822-183	3822-183	3822-183	3822-183	3822-183	3822-183
60	Washer, Cyl. Rod	7437-009	7437-153	7437-153	7437-202	7437-202	7489-015	7489-132
61	Screw, Soc. Hd. Cap	3303-111	3303-111	3303-111	3303-111	3303-129	3303-146	3303-146
62	Screw, Soc. Hd. Cap	3303-114	3303-130	3303-130	3303-130	3303-130	3303-164	3303-165
63	Plug, Orifice 0.062	7437-341	7437-341	7437-341	7437-298	7437-298	7437-341	7437-341
64	O-Ring	3255-201	3255-246	3255-246	3255-250	3255-252	N/A	N/A
65	Cap, Cylinder Top	7437-422	7437-666	7437-666	7442-014	7437-687	N/A	N/A
66	O-Ring, Backup	3255-418	3255-442	3255-442	3255-445	3255-447	N/A	N/A
67	O-Ring	3255-199	3255-248	3255-248	3255-251	3255-254	N/A	N/A
68	Cover, R.H. Cylinder	7437-472	7437-454	7437-454	7437-659	7437-526	7489-041	7489-136
68A	Cover, L.H. Cylinder	7437-473	7437-455	7437-455	7437-660	7437-527	7489-042	7489-137
69	Housing, Cylinder	7437-421	7437-665	7437-665	7442-015	7437-689	7489-048	
70	O-Ring	3255-177	3255-182	3255-182	3255-177	3255-182	3255-184	3255-184
71	O-Ring	3255-104	3255-104	3255-104	3255-104	3255-110	N/A	N/A
73	Valve, Cart.	3760-040	3760-017	3760-017	3760-017	3760-017	3760-045	3760-045
74	O-Ring	3255-112	3255-121	3255-121	3255-121	3255-121	3255-184	3255-184
75	O-Ring, Backup	3255-420	3255-322	3255-322	3255-322	3255-322	3255-421	3255-421
76	Retainer, Fill Valve Spring	7437-433	7437-437	7437-437	7437-468	7437-468	7489-029	7489-145
77	Spring, Valve	3510-500	3510-510	3510-510	3510-510	3510-510	3510-520	3510-520
78	Screw, Soc. Hd. Cap	3303-630	3303-633	3303-633	3303-633	3303-633	3303-690	3303-690
79	Cap, Fill Valve	7437-427	7437-432	7437-432	7437-432	7437-432	7489-028	7489-028
80	Bearing, Piston	3188-006	3188-017	3188-017	3188-025	3188-032	3188-033	3188-040
81	Seal, Glyd. Ring Piston	3211-821	3211-832	3211-832	3211-840	3211-844	3211-845	3211-850
82	Rod, Cylinder Piston	7437-385	7437-436	7437-436	7437-384	7437-479	7489-020	
83	O-Ring	3255-210	3255-235	3255-235	3255-252	3255-255	3255-229	3255-264
84	O-Ring, Backup	3255-429	3255-435	3255-435	3255-446	3255-448	3255-437	3255-461
85	Cap, Cylinder Rod	7437-275	7437-667	7437-667	7437-782	7437-688	7489-021	7489-122
86	Bearing, Rod	3188-006	3188-009	3188-009	3188-027	3188-028	3188-031	3188-041
87	Stepseal, Cylinder Rod	3211-818	3211-819	3211-819	3211-829	3211-841	3211-843	3211-849
88	Wiper, Cylinder Rod	3211-692	3211-712	3211-712	3211-830	3211-721	3211-723	3211-728
89	Stud, Cylinder to Ram	7437-013	7437-154	7437-154	7437-201	7437-201	7489-016	7489-133
90	Poly, Pack, Rod Seal	3211-802	3211-803	3211-803	3211-829	3211-837	3211-842	3211-848

# LINEAR ENCODER

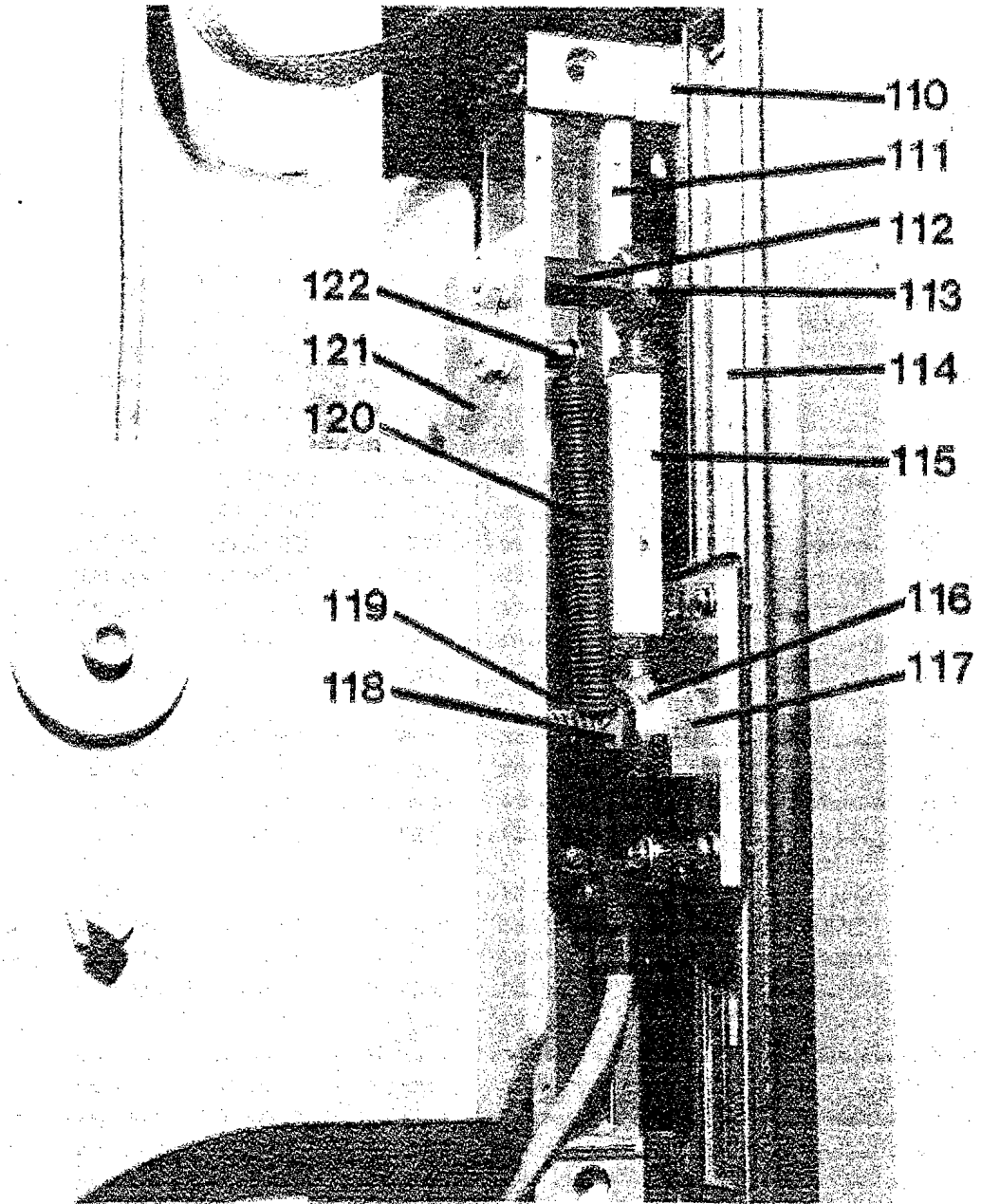

# LINEAR ENCODER

	DESCRIPTION	XCELL 60	XCELL 100	XCELL 140	XCELL 175	XCELL 250	XCELL 400	XCELL 500
110	Spacer, Scale Unit	N/A	N/A	N/A	N/A	7437-545	7437-545	7437-545
110A	Pad, Scale Mounting	N/A	N/A	N/A	N/A	7437-523	7437-523	7437-523
111	Encoder, Linear	3900-170	3900-100	3900-100	3900-100	3900-270	3900-270	3900-270
112	Stud, Rod End - Upper	7437-359	7437-349	7437-349	7437-349	7437-349	7437-349	7437-349
113	Rod End, R.H. Thd.	3132-254	3132-254	3132-254	3132-254	3132-254	3132-254	3132-254
114	Bearing, Slide Packunit	3162-010	3162-099	3162-099	3162-099	3162-101	3162-101	3162-101
115	Turnbuckle	7437-350	7437-350	7437-350	7437-350	7437-350	7437-350	7437-350
116	Rod End, L.H. Thd.	3132-255	3132-255	3132-255	3132-255	3132-255	3132-255	3132-255
117	Plate, Scanning Head Mtg.	7437-343	7437-524	7437-524	7437-524	7437-524	7437-524	7437-524
118	Stud, Spring - Lower	7437-348	7437-529	7437-529	7437-529	7437-529	7437-529	7437-529
119	Spring, Compression	3504-097						
120	Spring, Extension	3506-151	3506-151	3506-151	3506-151	3506-151	3506-151	3506-151
121	Plate, Encoder Linkage	7437-353	N/A	N/A	N/A	N/A	N/A	N/A
122	Stud, Spring Mtg.	7437-358	7437-347	7437-347	7437-347	7437-347	7437-347	7437-347

# F800 CNC BACK GAUGE

## GF-8 PARTS LIST

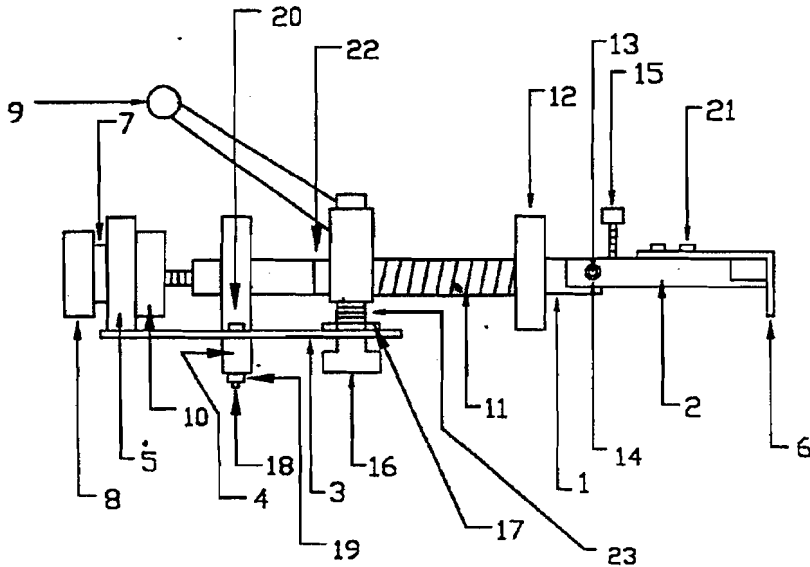

### GF-8 FIG. BB PARTS LIST

ITEM	PART NUMBER	DESCRIPTION
1	2236-301	FINGER ROD
2	2236-302	FLIP FINGER
3	2236-303	FINGER PLATE
4	2236-304	FINGER KEY 1/2 X 5/8 X 3
5	2236-305	SHAFT COLLAR (MACHINED)
6	2236-306	TIP ADAPTER
7	2236-307	FLAT WASHER
8	2236-308	KNURLED HEAD SCREW
9	2236-309	RATCHET HANDLE
10	2236-310	KNURLED NUTS
11	2236-311	SPRING
12	2236-312	SHAFT COLLAR
13	2236-313	SOCKET SET SCREW
14	2236-314	LOCK RING
15	2236-315	CAP SCREW (PATCH)
16	2236-316	TEE NUT
17	2236-317	WASHER FLAT
18	2236-318	HALF DOG
19	2236-319	HEX NUT
20	2236-320	BUTTON HEAD CAP SCREW
21	2236-321	BUTTON HEAD CAP SCREW
22	2236-322	SNAP RING
23	2236-323	SOCKET SET SCREW

# F800 CNC BACK GAUGE

## UPRIGHT ASSEMBLY

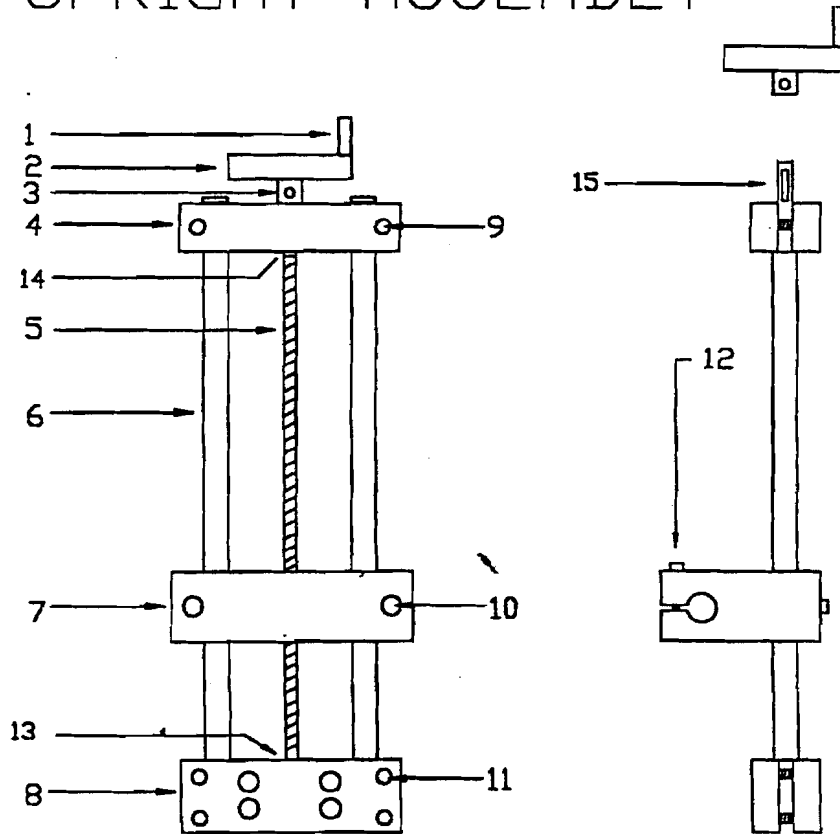

**UPRIGHT ASSEMBLY FIG NN**

ITEM	PART NUMBER	DESCRIPTION
1	2236-401	HAND
2	2236-402	HANDWHEEL
3	2236-403	SET SCREW
4	2236-404	TOP CLAMP
5	2236-405	VERTICAL LD.SC.
6	2236-406	VERTICAL SHAFT
7	2236-407	ELEVATION BLK.
8	2236-408	BOTTOM CLAMP
9	2236-409	SOC CAP SCREWW
10	2236-410	SOC CAP SCREW
11	2236-411	SOC CAP SCREW
12	2236-412	SHCS
13	2236-413	BALL
14	2236-414	WASHER
15	2236-415	WOODRUFF KEY

# F800 CNC BACK GAUGE

## PARTS LIST FOR FIGURES GG, HH, II, JJ, KK, LL, MM

ITEM	PART NUMBER	DESCRIPTION
1	2236-001	LEFT CASTING
2	2236-002	RIGHT CASTING
3	2236-003	FRONT PLATE
4	2236-004-B	END CAP (G/24-B)
	2236-004-HD	END CAP (G/24-HD)
	2236-004-TD	END CAP (G/24-TD)
5	2236-005	BRAKE WIRE CHANNEL
6	2236-006	HARDENED WAY
7	2236-007	ROLL PIN
8	2236-008	BALL SCREW
9	2236-009	BALL NUT
10	2236-010	BALL NUT PLATE
11	2236-011	BALL NUT BLOCK
12	2236-012	BRAKE ARMATURE
13	2236-013	BRAKE DISC.
14	2236-014	BEARING RETAINER
15	2236-015	BEARING
16	2236-016	THD SHAFT COLLAR
17	2236-017	COUPLING, RIGID
18	2236-018	REAR PLATE
19	2236-019	REAR PLATE COVER
20	2236-020	CARRIER PLATE
21	2236-021	BALL BUSHING
22	2236-022	BALL BUSHING
23	2236-023	EXTENDER
24	2236-024	RIGHT ANGLE DRIVE CROWN
25	2236-025-B	CONNECTING ROD (G/24-B)
	2236-025-HD	CONNECTING ROD (G/24-HD)
	2236-024-TD	CONNECTING ROD (G/24-TD)
26	2236-026	ROD SUPPORT
27	2236-017	COUPLING, RIGID
28		MOTOR H-344-H-0802
29	2236-029	MOTOR BRACKET
29A		X-MOTOR ADAPTER
30	2236-030	MOTOR COVER
31	2236-031	COVER BLOCK
33	2236-033	LIMIT SWITCH
34	2236-034	DRIVE BELT
35	2236-035	DRIVE SPROCKET
36	2236-036	DRIVEN SPROCKET
46	2236-046	MOUNT. HARDWARE
47	2236-047	MOUNT. HARDWARE
48		MOUNT. HARDWARE CONT. BOX
49	2236-049	MOUNT HARDWARE
50	2236-050	WORK BLOCK
53	2236-053	REF. BLOCK
58	2236-058	GAUGE BAR SUPPORT
59	2236-059	SLIDER ROD
60	2236-060	TEE BOLT
61	2236-061-B	GAUGE BAR S.E. (G/24-B)
	2236-061-HD	GAUGE BAR S.E. (G/24-HD)
	2236-061-TD	GAUGE BAR S.E. (G/24-TD)

# F800 CNC BACK GAUGE: FIG. GG

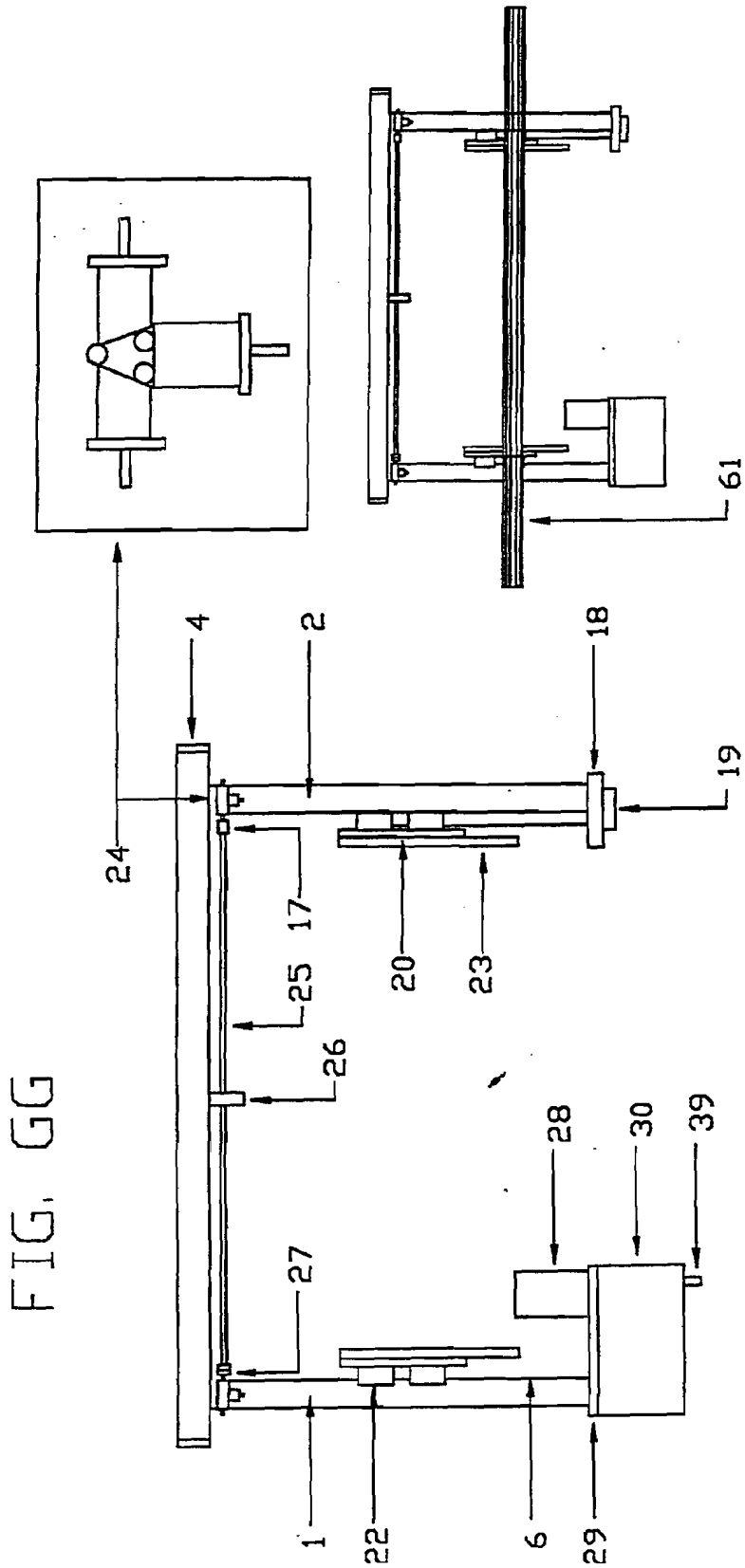

# F800 CNC BACK GAUGE: FIG. HH

FIG. HH

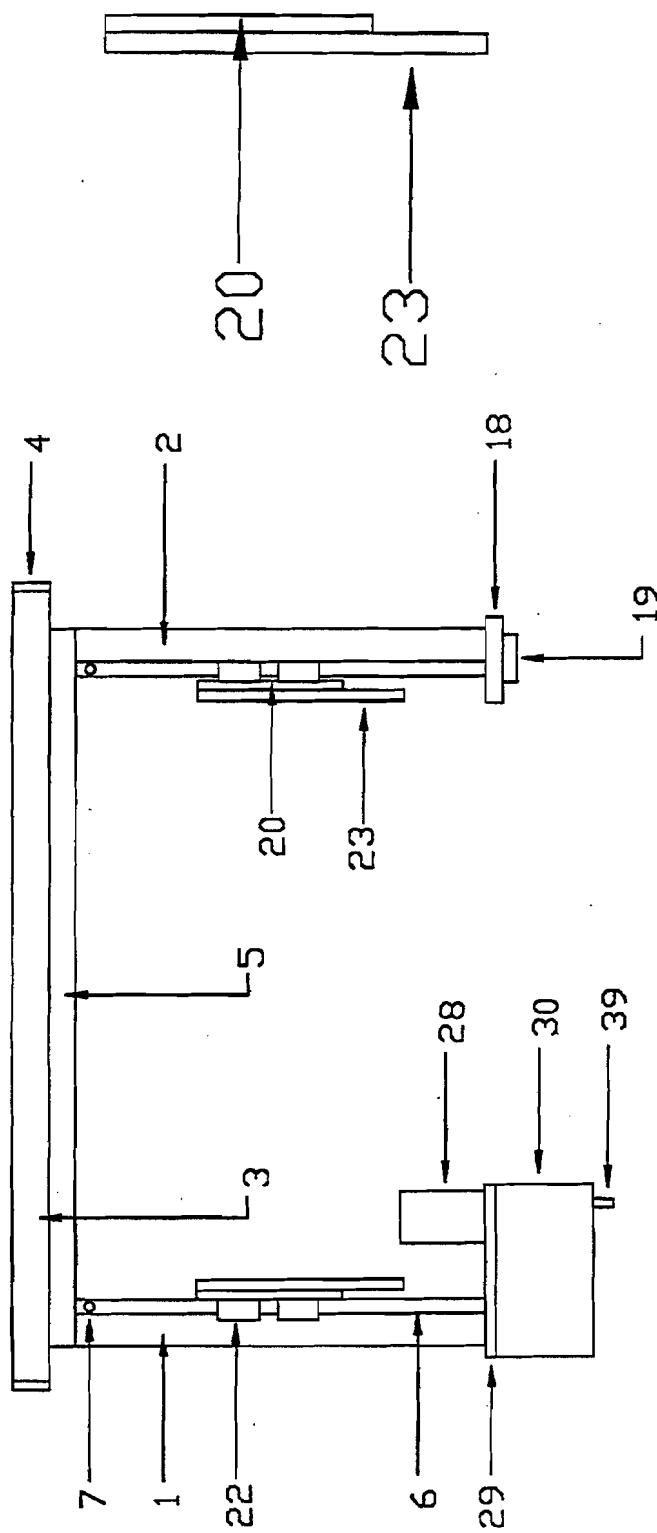

# F800 CNC BACK GAUGE: FIG. II

FIG. II

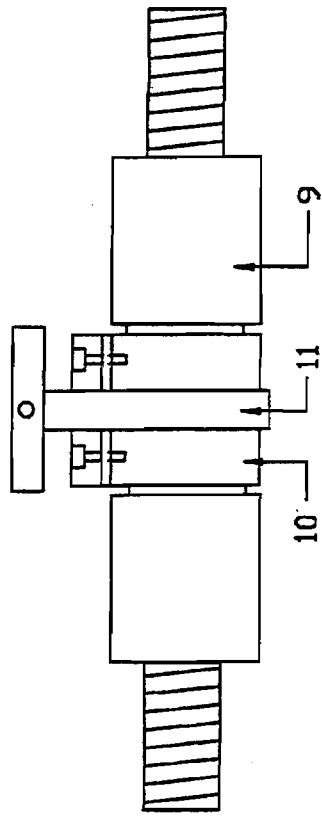

BALL NUT ASSEMBLY

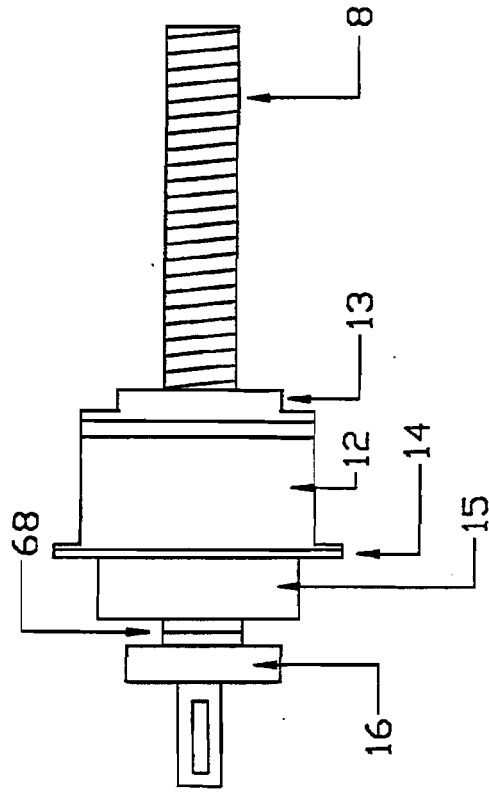

BRAKE ASSEMBLY

F800 CNC BACK GAUGE: FIG. JJ

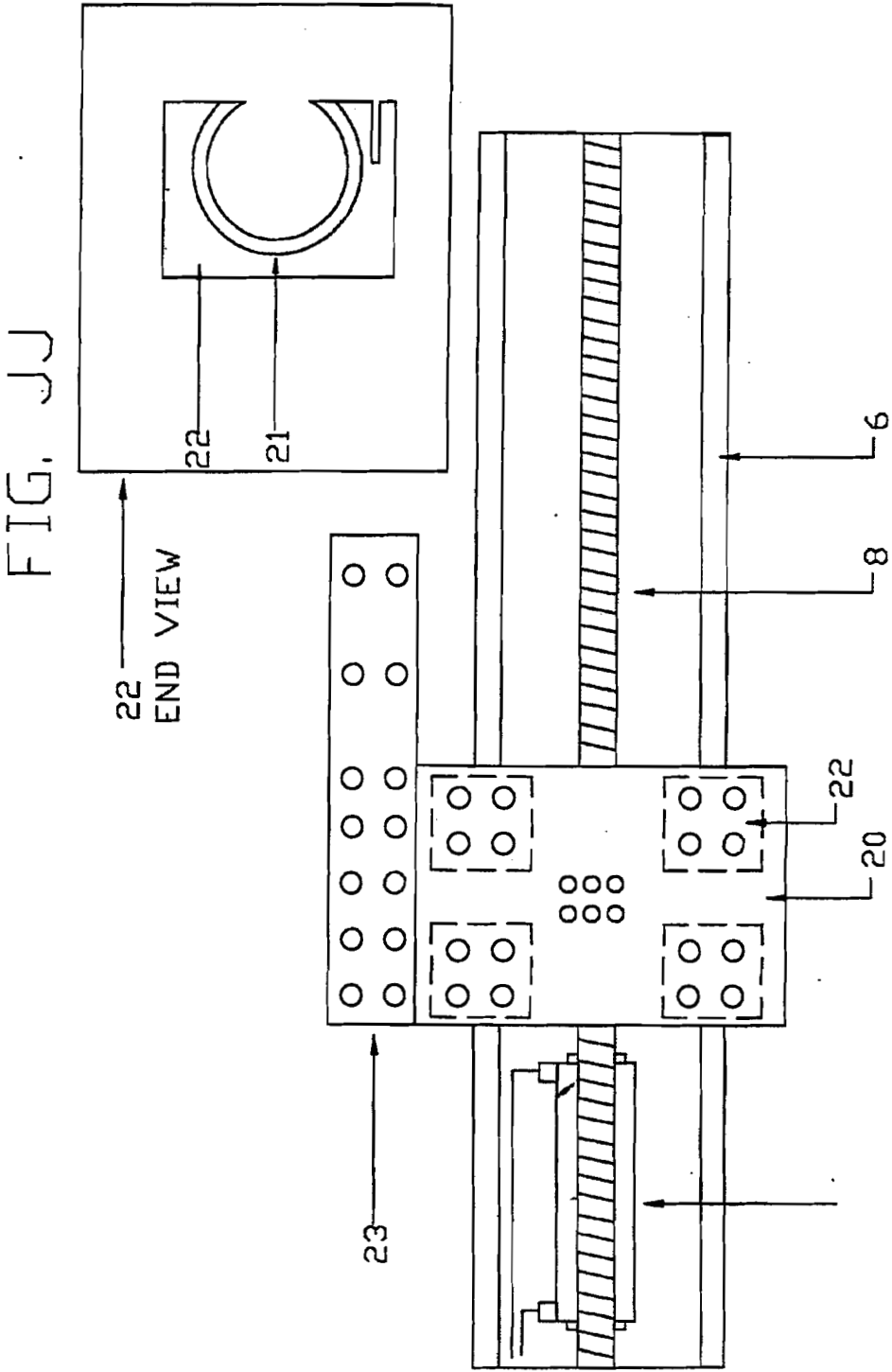

# F800 CNC BACK GAUGE: FIG. LL

FIG. LL

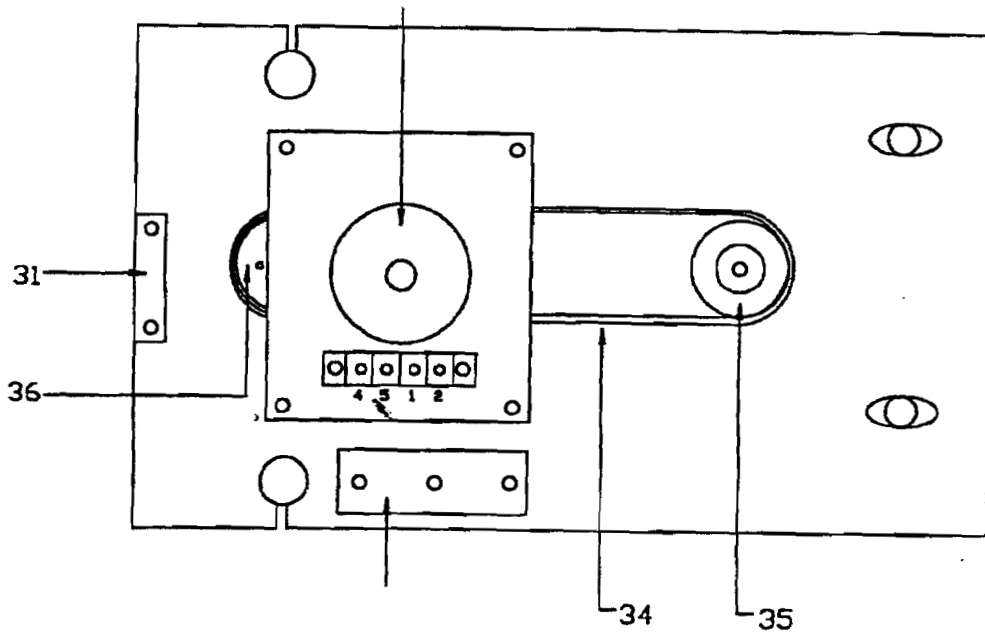

F800 CNC BACK GAUGE: FIG. MM

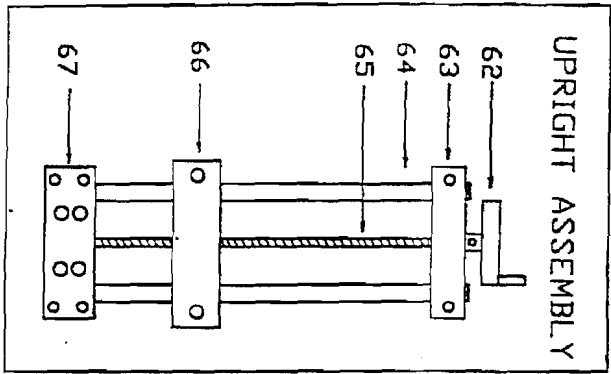
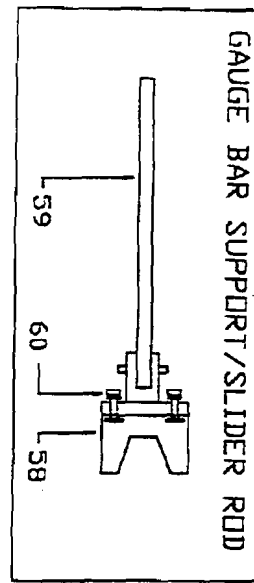
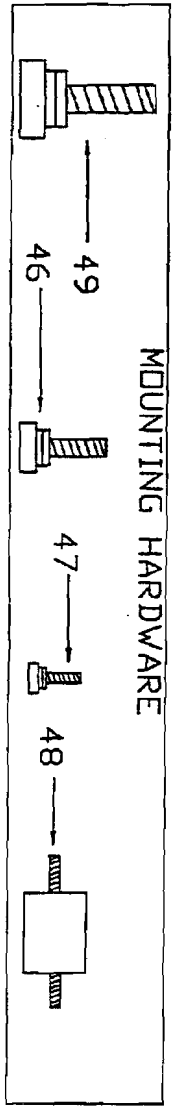
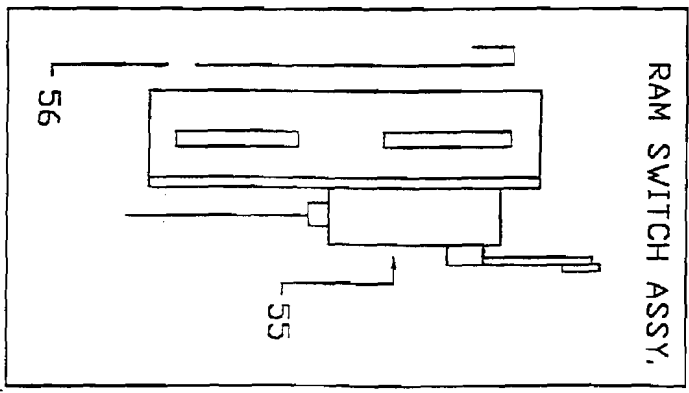
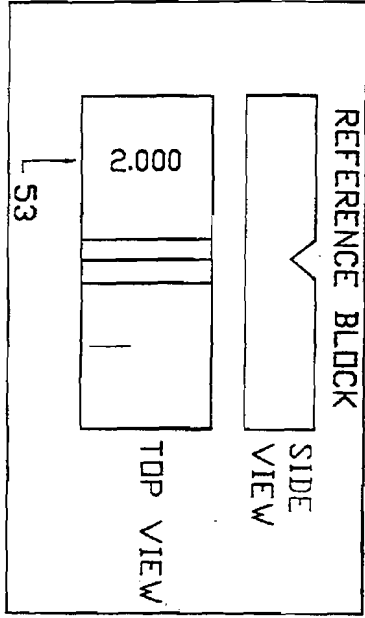
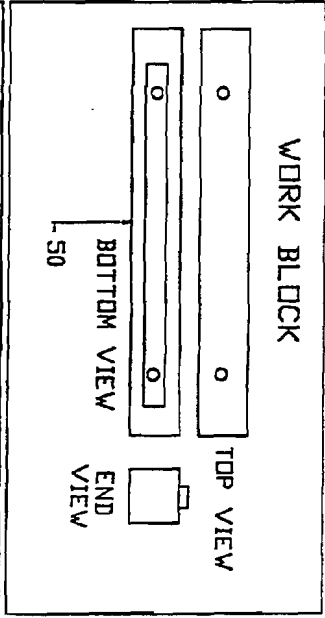

FIG. MM



# F800 CNC BACK GAUGE:

## R AXIS PARTS LIST FOR FIGURES 82, 83, 84

ITEM	PART NUMBER	DESCRIPTION
75	2236-075	ELEVATION BLOCK
76	2236-076	UPPER CLAMP
77	2236-077	LOWER CLAMP
78	2236-078	BALL SCREW
79	2236-079	BALL NUT
80	2236-080	BALL NUT PLATE
81	2236-081	SPROCKET
82	2236-082	BELT
83	2236-083	HAND WHEEL
84	2236-084	COUPLING
87	2236-087	32 AD MOTOR BKT
88	2236-088	SWITCH ACTUATOR
89	2236-089	MTR BKT COVER
90	2236-90	BELT GUARD
91	2236-91	G. BOX SUP. L&R
92	2236-092-HD	CHAN HD
93	2236-093-B	CHAN B
94	2236-094-TD	CHAN BPG
95	2236-095	CON ROD CVR (CHAN) HD
96	2236-096	CON ROD CVR (CHAN)B
97	2236-097	CON ROD CVR (CHAN) BPG
98	2236-098	CON ROD SUP (ALL SYS)
99	2236-099	CON ROD CVR
100	2236-100	BEARING
101	2236-101	SHAFT
102	2236-102	SPROCKET
105	2236-105	GEAR BOX
106	2236-106-B	CONNECTING ROD (G/24-B)
	2236-106-HD	CONNECTING ROD (G/24-HD)
	2236-106-TD	CONNECTING ROD (G/24-TD)
107	2236-107	FLEXIBLE COUPLING
108		LIMIT SWITCH
109	2236-109	SCREW (SHCS) (4)
110	2236-110	SCREW (BUTTON) (6)
111	2236-111	SCREW (SET) (2)
112	2236-112	SCREW (SHCS) (4)
113	2236-113	HEAVY F/W (4)
114	2236-114	LOCK WASHER (4)
115	2236-115	WOODRUFF KEY (3)

F800 CNC BACK GAUGE: FIG. 82

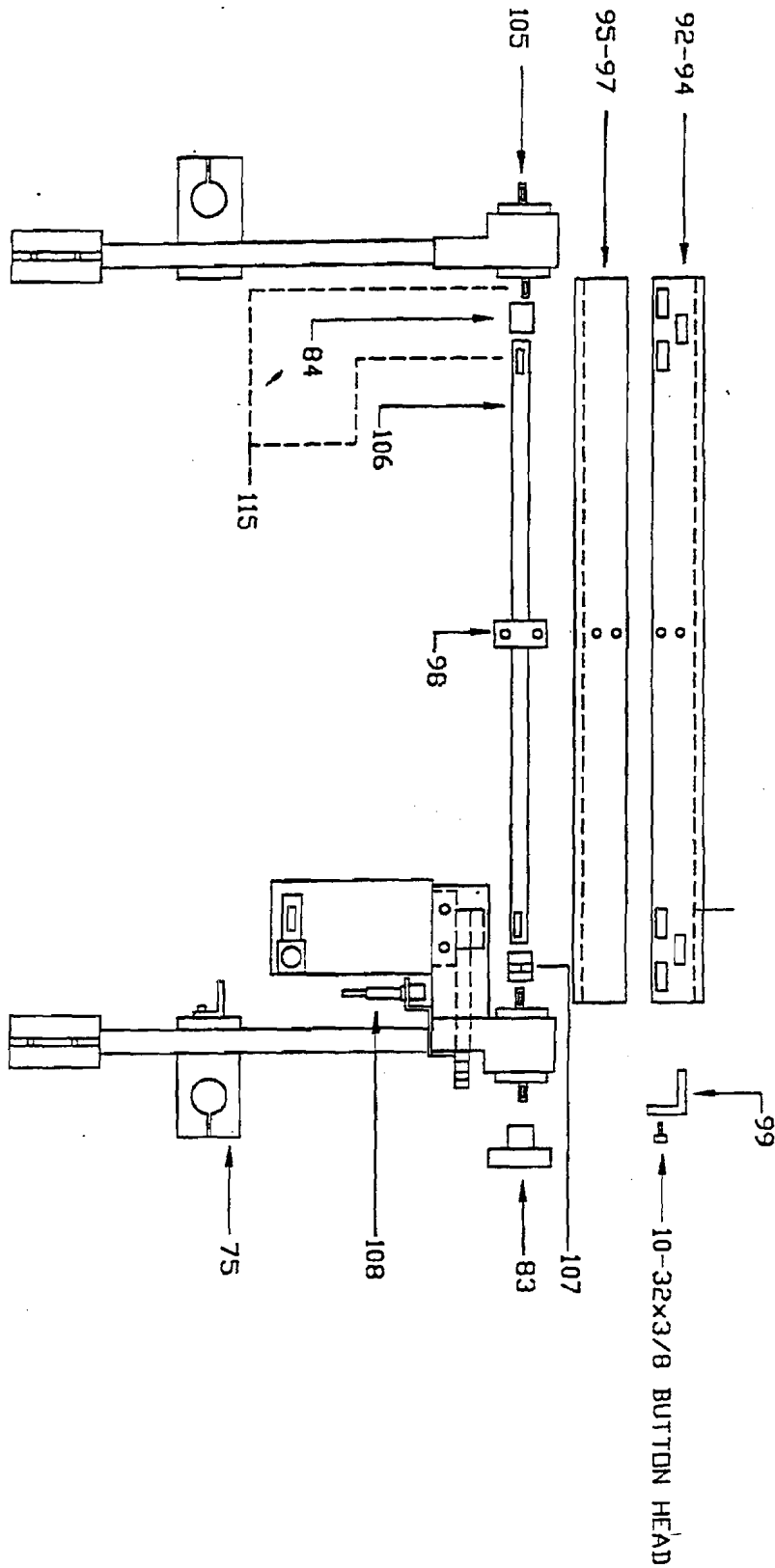



# F800 CNC BACK GAUGE: FIG. 84

